

SERIES:

MGDN2



3003 9th Avenue SW  
 PO Box 50  
 Watertown, SD 57201  
 Toll free: 888-978-2638  
 Ph: 605-886-3326  
 Fax: 605-886-8995



Low Profile, High Current Power Inductors

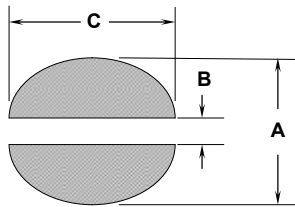

Suggested Land Pattern

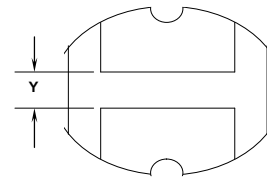
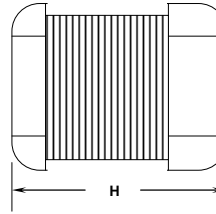
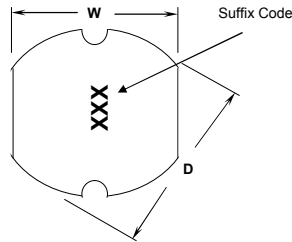

Series Number	Maximum Dimensions				Reference Dimensions			
	Units	L	W	H	Y	A	B	C
MGDN2	inches	0.240"	0.217"	0.193"	0.051"	0.268"	0.051"	0.217"
	[ mm ]	[ 6.10 ]	[ 5.50 ]	[ 4.90 ]	[ 1.30 ]	[ 6.80 ]	[ 1.30 ]	[ 5.50 ]

Features:

- High energy storage and low resistance
- Reliable surface mounting, flat top for pick and place.
- Smaller real estate than other common inductors.
- Robust temperature deflection to prevent damage during solder reflow.
- Tape and Reel mechanical specifications available upon request.
- Operating Temperature -40°C to +85°C.
- Highly resistive core for EMI suppression applications.

Notes:

- Inductance measured at 100kHz and 250mVrms.
- Isat is a maximum applied AC + DC current.
- Isat current is applied to produce a typical 35% drop in nominal inductance.
- Tolerance suffix of M = ±20%.
- DCR is a maximum at 20°C.

260°C Maximum reflow temperature per J-STD020  
 Terminal Plating is Hot Dipped SnAgCu



Schematic Diagram

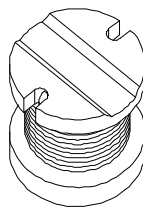
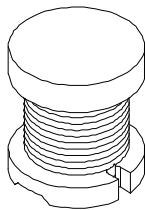
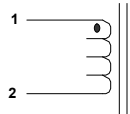

Contact CoEv for additional inductance values

MGDN2				
Lead Free Part Number	L $\mu$ H	DCR	IsAT	Tolerance
		W	A	Suffix
	1.0			
	1.4			
	1.8			
	2.2			
	2.7			
	3.3			
MGDN2-00001	3.9	0.07	3.2	M
	4.7			
	5.6			
MGDN2-00002	6.8	0.08	1.6	M
	8.2			
MGDN2-00003	10	0.10	1.44	M
MGDN2-00004	12	0.12	1.40	M
MGDN2-00005	15	0.14	1.30	M
MGDN2-00006	18	0.15	1.23	M
MGDN2-00007	22	0.18	1.11	M
MGDN2-00008	27	0.20	0.97	M
MGDN2-00009	33	0.23	0.88	L
MGDN2-00010	39	0.32	0.80	L
MGDN2-00011	47	0.37	0.72	L
MGDN2-00012	56	0.42	0.68	K
MGDN2-00013	68	0.46	0.61	K
MGDN2-00014	82	0.60	0.58	K
MGDN2-00015	100	0.70	0.52	K
MGDN2-00016	120	0.93	0.48	K
MGDN2-00017	150	1.10	0.40	K
MGDN2-00018	180	1.38	0.38	K
MGDN2-00019	220	1.57	0.35	K
	270			
	330			
	390			
	470			
	560			
	680			
	820			
	1000			

Specifications subject to change

Call Toll Free: 888-978-2638 Website: [www.tycopowercomponents.com](http://www.tycopowercomponents.com)

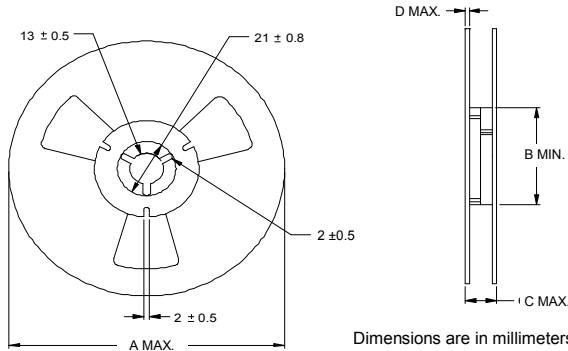

Series Number	Reel dimensions				Reel Qty	Carton (Box) Qty.	Packaging Specification
	Units	A	B	C			
MGDN2	in.	12.99"	4.02"	0.87"	1000	6000	90-0050
	[mm]	[330]	[102.0]	[22.2]			

PACKAGING NOTE: Only pressure sensitive cover tape is to be used.

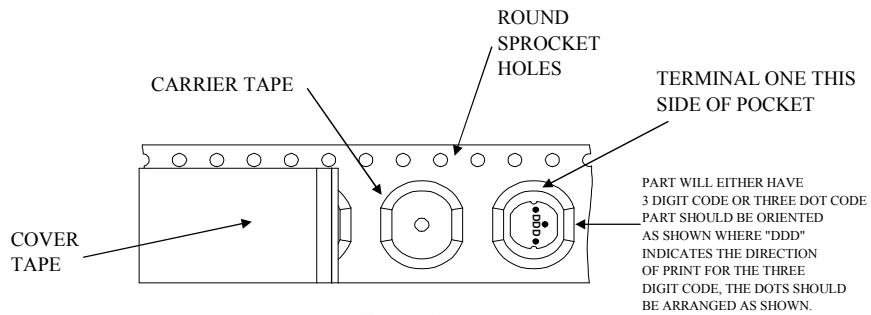
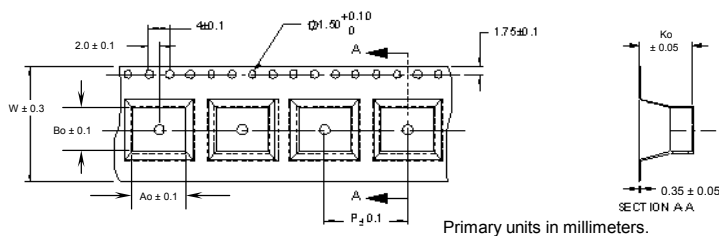

FIGURE 1  
CARRIER TAPE AND PART



Series	Ao	Bo	W	P	Ko
MGDN2	5.40	6.10	16.0	12.0	5.30



Customer Packaging Specifications  
For Print Distribution to Customers

Series	Revision
MGDN2	A0
Sheet 2 of 3	

Item	Specification	Test Method/Condition
<b>Environmental</b>		
Static Humidity	After exposure part remains within specified electrical parameters for L, Q and DCR.	Expose parts to an environment of +50°C with 90 to 95% R.H. for 100 hours. After exposure, allow parts to dry for 2 hours before measurements are taken.
Storage Life	After exposure part remains within specified electrical parameters for L, Q and DCR.	Subject parts to an environment of +50°C 90 to 100% R.H. for 46 to 50 hours. After exposure, allow parts to dry for 2 hours before measurements are taken.
Moisture Resistance	After exposure, part shall not have a shorted or open winding.	Per MIL-STD 202 Method 106, ten 24 hour cycles at +25°C to +65°C at 80 to 95% R.H. During any of the first 9 cycles, inductors are revolved from the chamber and exposed to -10°C for 3 hours. Allow parts to dry for 2 hours before measurements are taken.
Temperature Cycle	After exposure part remains within specified electrical parameters for L, Q and DCR.	10 cycles (Air to Air) 1 cycle shall consist of: 30 minutes exposure to +85°C 30 minutes exposure to -40°C Allow 20 minutes transition between extremes.
Temperature Shock	After exposure part remains within specified electrical parameters for L, Q and DCR.	10 cycles (Air to Air) 1 cycle shall consist of: 30 minutes exposure to -45°C 30 minutes exposure to +125°C 15 seconds maximum transition between temperatures
<b>General</b>		
Storage Temperature Range	-40°C to +85°C	
Operating Temperature Range	-40°C to +85°C	
Flammability	IEC 695-2-2	Withstands needle-flame test
<b>Other</b>		
Vibration	After exposure part remains within specified electrical parameters for L, Q and DCR.	Inductors shall be randomly vibrated per NAVMAT P9492 profile. Samples shall be subjected to 0.04G/Hz for a minimum of 15 minutes per axis, for each of the three axes.
Mechanical Shock	After exposure part remains within specified electrical parameters for L, Q and DCR.	Test per MIL-STD 202 method 213 test condition A, test mounted samples 3 axes, 6 times, totaling 18 shocks. (50Gs, 11ms, half-sine).
Solderability	Wetting shall cover 90% minimum of each termination	Dip pads in RMA flux, 63/37 solder (Sn/Pb) at 232°C for 5 seconds ±2 seconds.
Component Adhesion (Push Test)	4 pounds	Apply and measure force with a digital force gauge set.
Resistance to Solvent	No sign of degradation in appearance or marking detail.	Withstands 6 minutes of alcohol. Withstands 3 minutes forced spray Freon TMS
Load Life	After exposure, part shall not have a shorted or open winding.	Parts to be stored at 110°C for 1000 hours with rated current applied. Parts to be tested at: start, 500 and 1000 hours. Allow 2 hours at room temperature before testing.



RoHS Compliant

**For Print Distribution to Customers**

Series	Revision
<b>MGDN2</b>	<b>A0</b>
Sheet 3 of 3	